

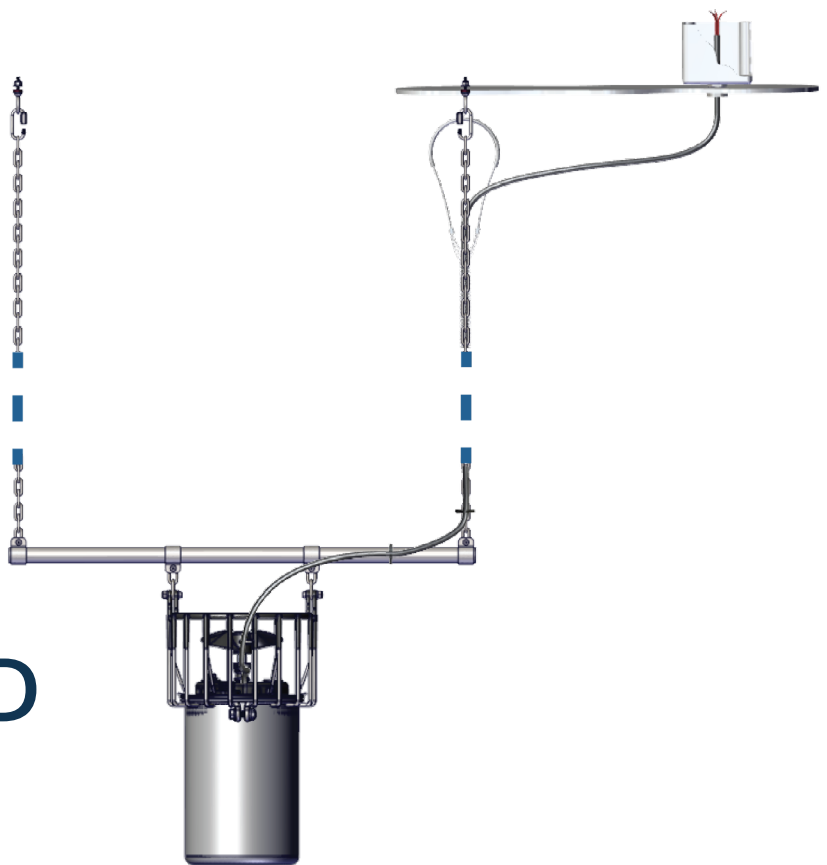

SM-50 SUSPENDED MOUNT



Assembly & Installation Manual



Document number 852114
Document version number 2022.1.0

800 Deere Rd. Prescott, WI 54021 | 715.262.4488 | sales@kascomarine.com | kascomarine.com

TABLE OF CONTENTS

Safety First.....	2
Product & Installation Overview.....	3
Suggested Tools and Supplies.....	4
Parts Included List.....	5
Parts Included Illustration.....	6
Tank Penetration.....	7
Stretcher Bar Assembly.....	9
Suspension Chains and Power Cable.....	10
Cable Support.....	11
Mixer Maintenance Recommendations.....	12
Mixer Warranty.....	13
Non-warranty Repairs.....	14
Repair Contact Form.....	15

QUESTIONS?



715.262.4488



kascomarine.com | sales@kascomarine.com

SAFETY FIRST

IMPORTANT: PLEASE READ THIS MANUAL AND SAVE FOR FUTURE REFERENCE

WARNINGS:



Moving Machinery



Shock Hazard

- Under NO circumstances should anyone enter the water with the mixer connected or in operation.
- Running the unit out of water will create a dangerous situation and damage the seals.
- NEVER lift the unit by the power cord. If you need to remove the mixer, use the installation or mount apparatus.
- The unit must be connected to a GFCI-protected circuit.
- Comply with local and national wiring standards during any electrical service disconnect.
- Consult a qualified professional for electrical installation.
- Use all Personal Protective Equipment necessary for safe ingress, installation, and egress from the work site.
- Refer to applicable national and local laws and standards to facilitate the safe installation of a CertiSafe Tank Mixer. These may include but are not limited to OSHA, CCOHS, and other regulations related to:
 - Working over or near water
 - Fall protection systems
 - Falling object protection systems
 - Electrical standards
 - Illumination
 - Ventilation
- Installation of CertiSafe™ Tank Mixers requires entry into environments that pose potential hazards, such as those described in section 1910.146 of OSHA's Occupational Safety and Health Standards for Permit-required confined spaces. As such:
 - Observe any applicable pre-entry measures required by the entry supervisor.
 - Only those authorized via the permit system in place at the installation site should participate in installation.
 - Any authorized entrant should be accompanied by at least one authorized attendant to monitor conditions inside and outside the permit spaces during installation.
 - Prior to installation, be aware of all potential fall, trip, and atmospheric hazards in the permit space, both before and after an entrance cover is removed.

PRODUCT & INSTALLATION OVERVIEW

Featuring durable stainless steel, Kasco's Suspended Mount positions CertiSafe™ Tank Mixers securely within the tank for effective water movement. This manual will provide instructions for mounting a CertiSafe™ unit using a Suspended Mount and installing the entire assembly within the tank.

- Read these instructions thoroughly prior to installation.
- Contact your CertiSafe™ representative for specific recommendations as necessary.
- The cord grip and cable support equipment described here are supplied with the mixer unit.
- To prevent galling, we recommend a moisture-cured, polyurethane compound sealant suitable for contact with potable water and certified to meet the shrinkage for interior and exterior use. Refer to NSF/ANSI Standard 61 for indirect additives.
- Be aware of clearance between the mixer assembly and any fixed objects within the tank, including ladders, ensuring that there is enough room for the CertiSafe™ unit to function correctly and avoid damage to any protective coatings.
- Please consult your CertiSafe™ sales representative for mixer mount placement, retrieval, and inspection requirements.

NOTE  Some parts will arrive pre-assembled from Kasco; however, all assembly steps are listed for reference.

This manual contains information for the SM-50 Suspended Mount.

SM-50

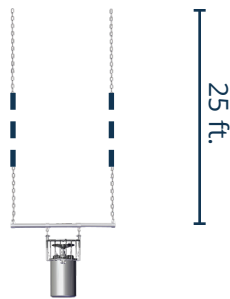

SUGGESTED TOOLS AND SUPPLIES

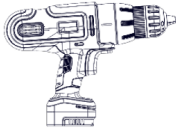

Electric or cordless drill



K (.281") drill bit



7/8" hole saw
or 1-7/64"
(for 10 AWG cord) hole saw



7/16" socket
wrench



9mm wrench
7/16" wrench



Half-round metal file



Pan to catch shavings



1/8" Allen wrench



Side cutter

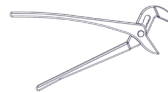

Adjustable pliers

PARTS INCLUDED LIST

Assembly	Item	Description	Qty	Part No.	
Mount	A	Stretcher bar (30 in.)	1	997311	
	B	Jaw slide	4	997206	
	C	1/4"-20 x 1/2" shoulder screw	4	451112	
	D	1/4"-20 x 3/4" shoulder screw	2	451110	
	E	1/4"-20 nylon locknut	6	566212	
	F	1/4" flat washer	8	566208	
	G	Long chain (25 ft.)	2	636384	
	H	Short chain	2	636383	
	I	Zip ties	12	415038	
Tank Penetration	J	1/4"-20 x 1" eye bolt	2	566224	
	E	1/4"-20 nylon locknut	2	566212	
	F	1/4" flat washer	4	566208	
	K	1/4" sealing washer	2	566223	
	L	Connecting link	2	636341	
			for use with Cord AWG		
Ships with CertiSafe™ mixer	M	Cord grip	14-16 AWG	1	997210
			12 AWG		997211
			10 AWG*		997212
	N	Cord grip nut	12-16 AWG	1	997215
			10 AWG		997216
	O	Cable support	10 AWG	1	997220
12-16 AWG			997221		

*Requires larger hole in tank roof (Ø 1-7/64")

PARTS INCLUDED ILLUSTRATION

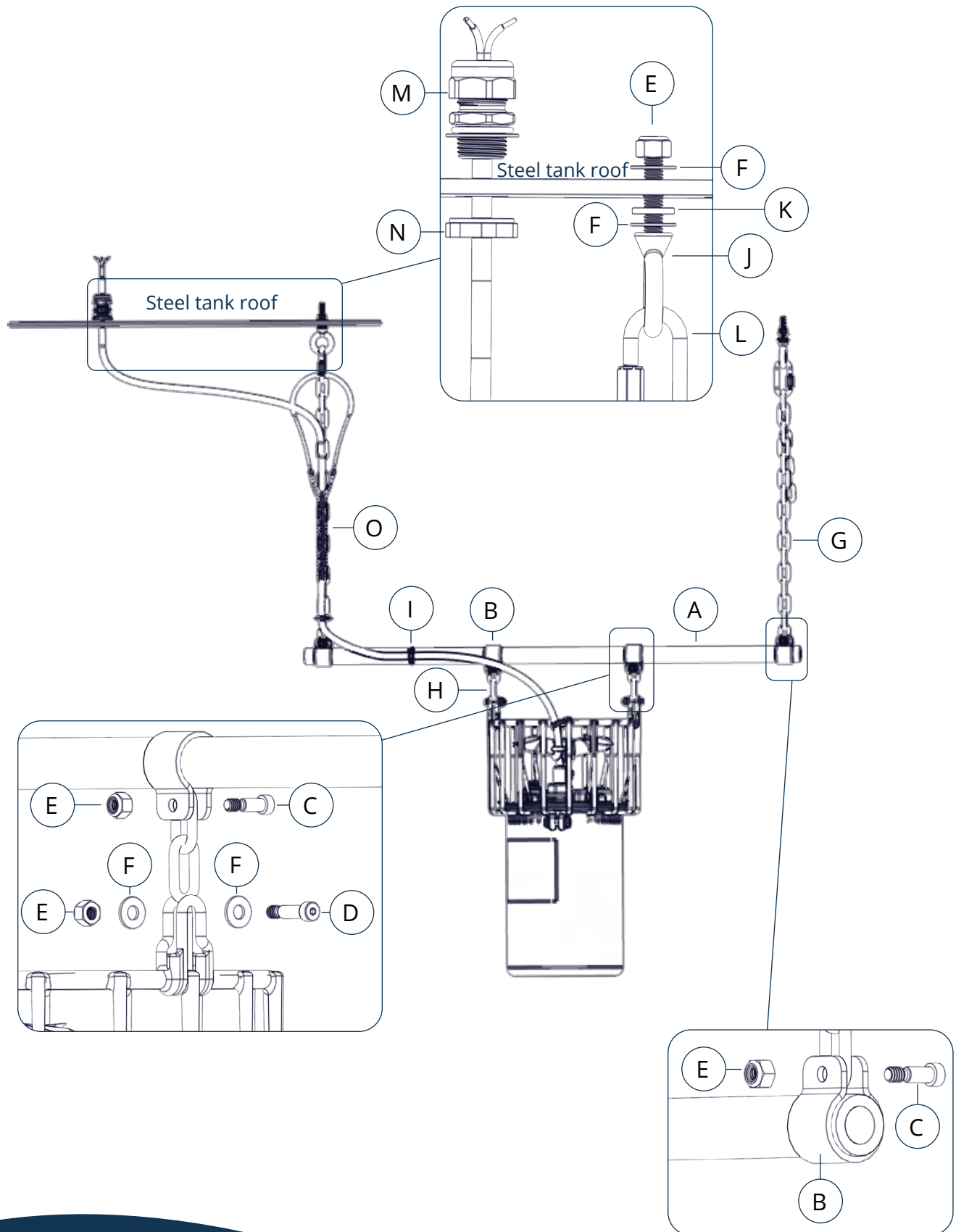

TANK PENETRATION



- The maximum tank roof thickness accommodated by the tank penetration parts included is 1/8".
- Suggested measurements are based on a 24" square access hatch.
- Using the tank hatch center point as reference, measurements indicate the horizontal distance from center for each mounting option.

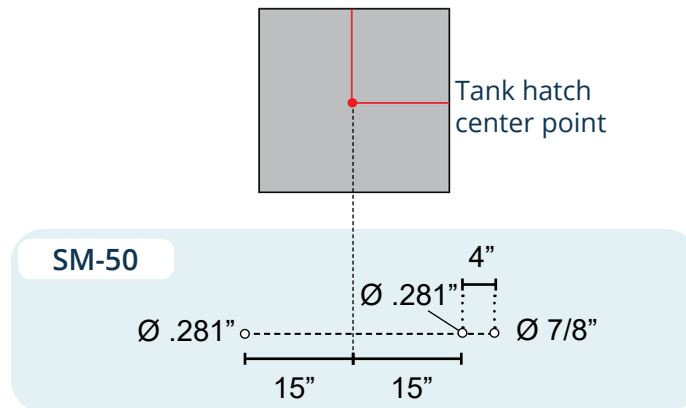

1. Drill two .281" clearance holes through the tank, 30" apart, each 15" from the tank hatch center point reference. These are for the eye bolts (J).
2. Deburr both sides of each hole.
3. Drill a 7/8" clearance hole approximately 4" from one of the holes drilled in step 1. This is for the cord grip (M).
4. Deburr both sides of the third hole.
5. From the tank exterior, pass the O-ringed side of the cord grip (M) through the 7/8" hole, with the O-ring outside the tank roof.
6. From the tank interior, fit the cord grip nut (N) on the threads protruding into the tank.
7. Tighten the nut until snug, being careful not to over-tighten.

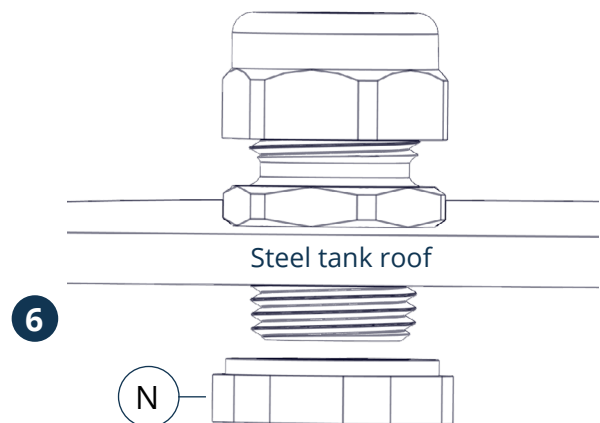
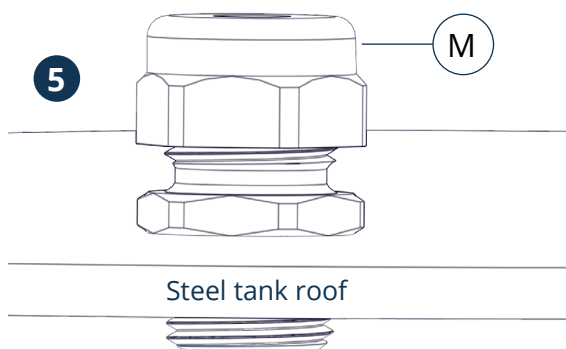

TANK PENETRATION (CONT.)

8. Fit a flat washer (F) and then the sealing washer (K) onto the eye bolt (J).
9. From the tank interior, insert the eye bolt with washers (K, F) through the 3/8" hole.
10. From the tank exterior, fit a second flat washer (F) onto the eye bolt.
11. Fasten a nylon locknut (E) to the eye bolt.
12. Tighten the locknut until snug, being careful not to damage the sealing washer.
13. Attach the top connecting link (L) to the eye bolt.

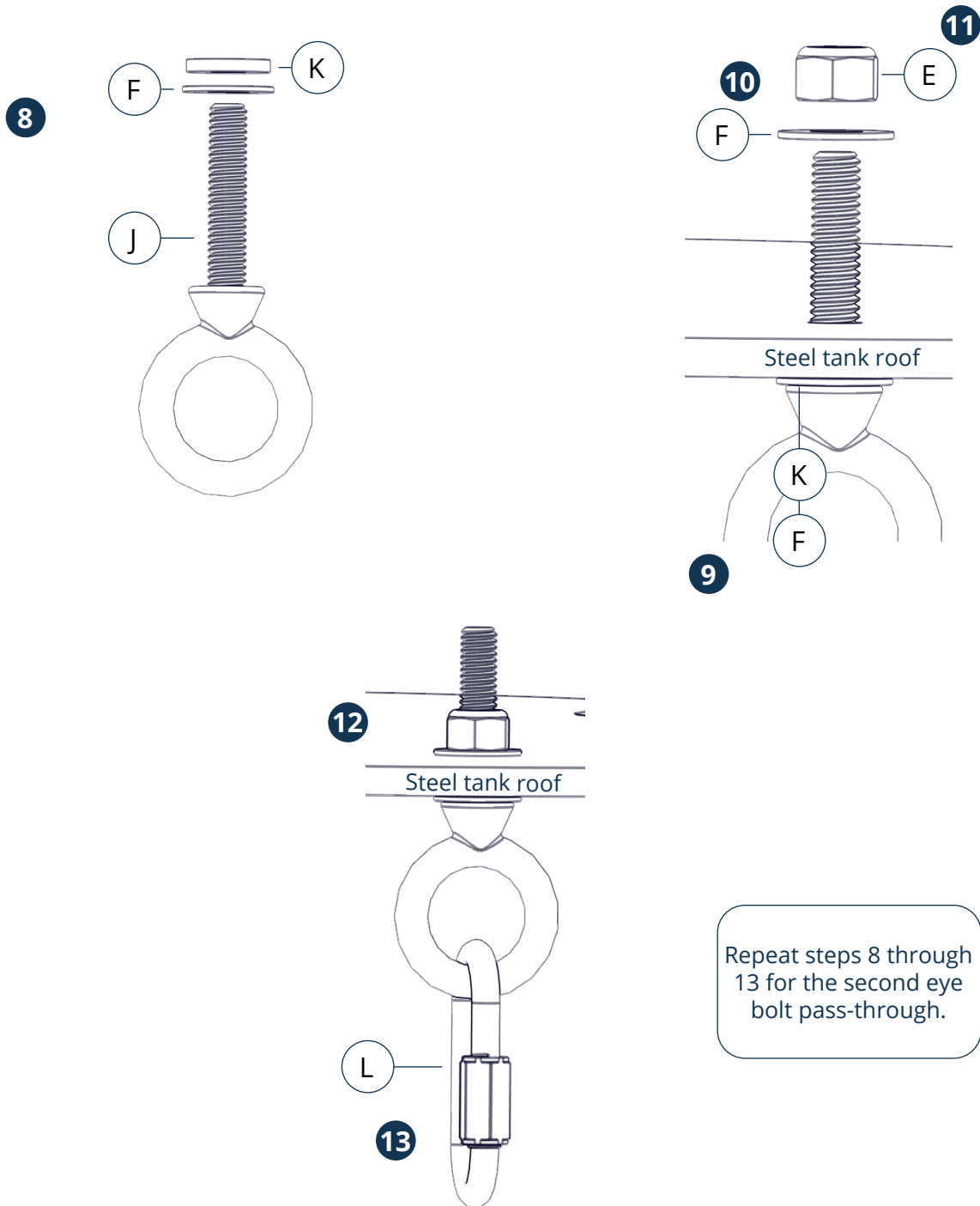

STRETCHER BAR ASSEMBLY

1. Insert the end link of a short chain (H) between the mixer cage loops on one side of the cage.
2. Secure the chain (H) with a shoulder screw (D), two washers (F), and locknut (E).
3. Repeat steps 1 and 2 for the other cage loop and short chain (H).
4. Tighten all locknuts until snug, without over-tightening.

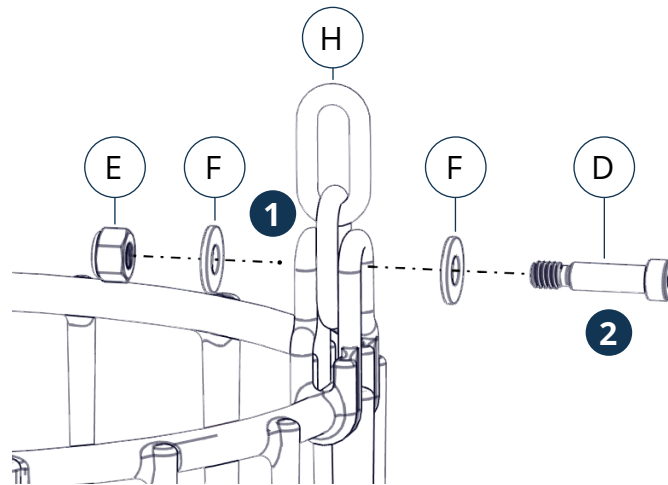

5. Insert one short chain loop (H) into an inner jaw slide (B) affixed to the stretcher bar (A).
6. Secure with shoulder screw (C) and locknut (E).
7. Repeat steps 5 and 6 for the second inner jaw slide (B), fastening the chain (H) with another shoulder screw (C) and locknut (E).
8. Tighten all locknuts until snug, without over-tightening.

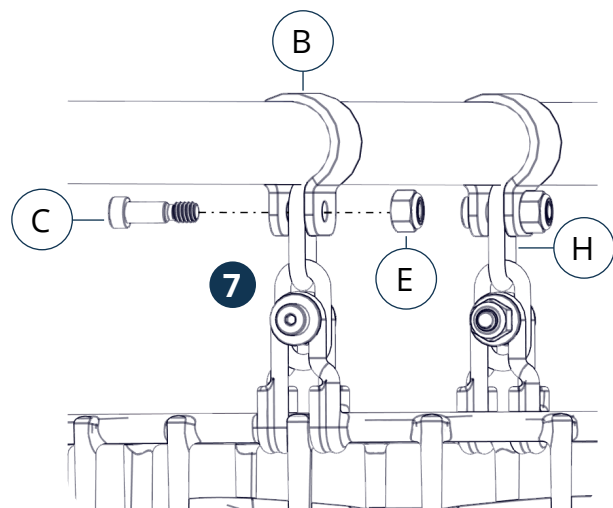
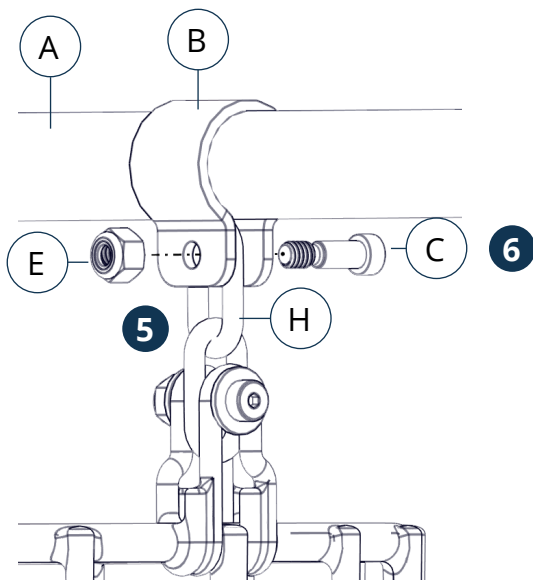

SUSPENSION CHAINS AND POWER CABLE

1. Insert one end link of a long chain (G) into an outer jaw slide (B) placed at the end of the stretcher bar.
2. Secure with a shoulder screw (C) and locknut (E).
3. Repeat steps 1 and 2 to secure the remaining long chain (G) at the opposite end of the stretcher bar (A).
4. Tighten stretcher bar fasteners, taking care not to over-tighten.
5. Use zip ties (I) to secure the power cord to the stretcher bar (A) in two places and to guide the cord around the corner where the bar meets the long chain, making sure not to put tension on the power cable.
6. Continue to apply the zip ties (I) every 4 feet along the long chain (G) and power cable length.

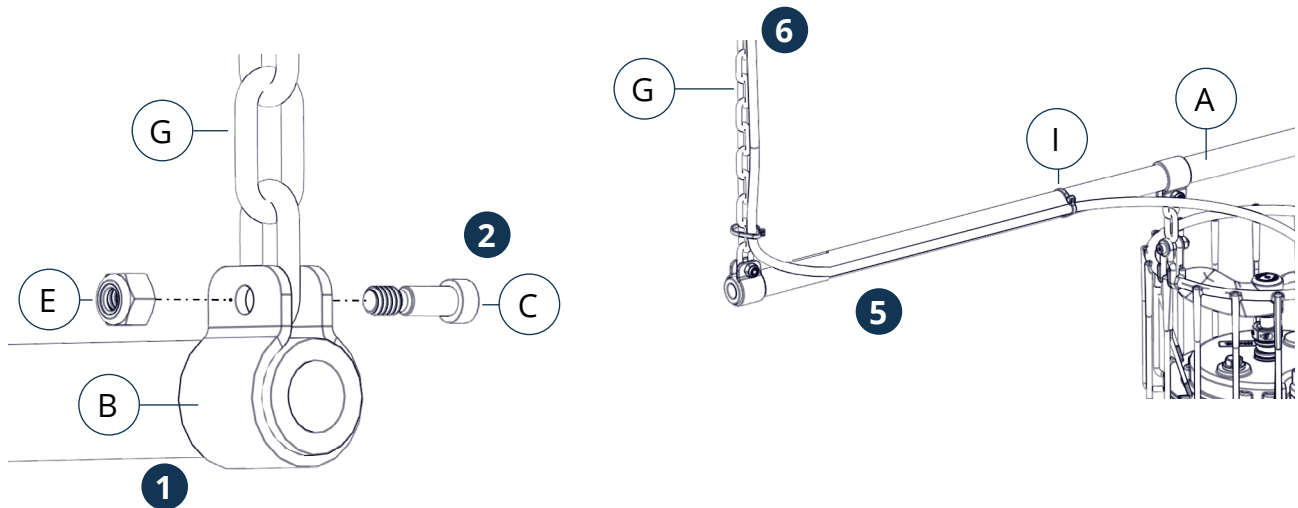

7. Attach the long chain (G) with the power cord to the connecting link (L) closest to the cord grip (M).
8. Attach the long chain (G) without the cord to the connecting link (L) farthest from cord grip (M).
9. Coil any excess chain and tie with wire.

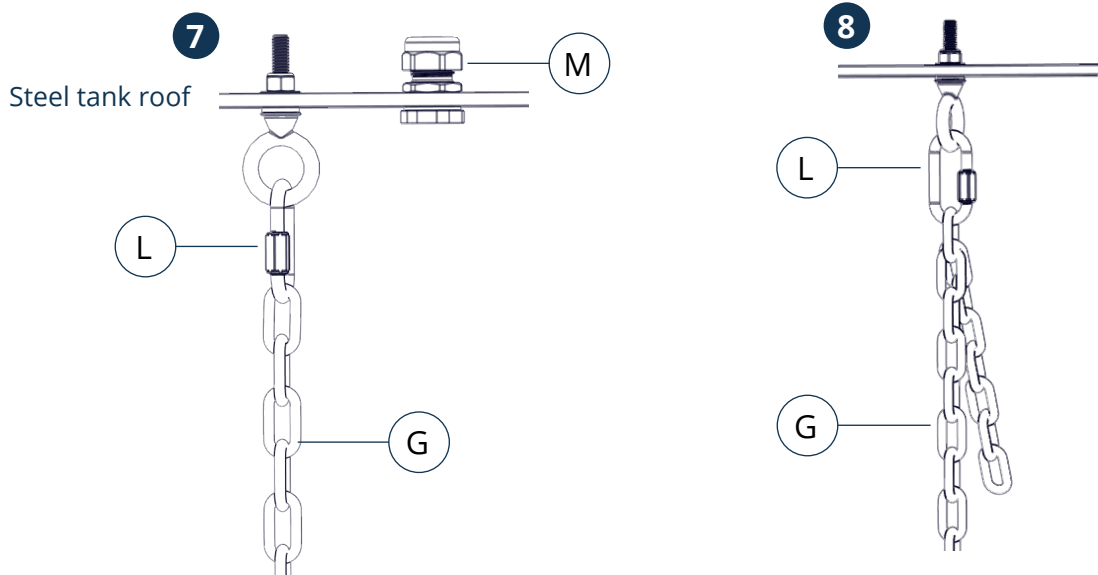

CABLE SUPPORT

1. Attach the cable support (O) to the connecting link (L).
2. Close and tighten the connecting link.
3. Feed power cable through the cable support (O).

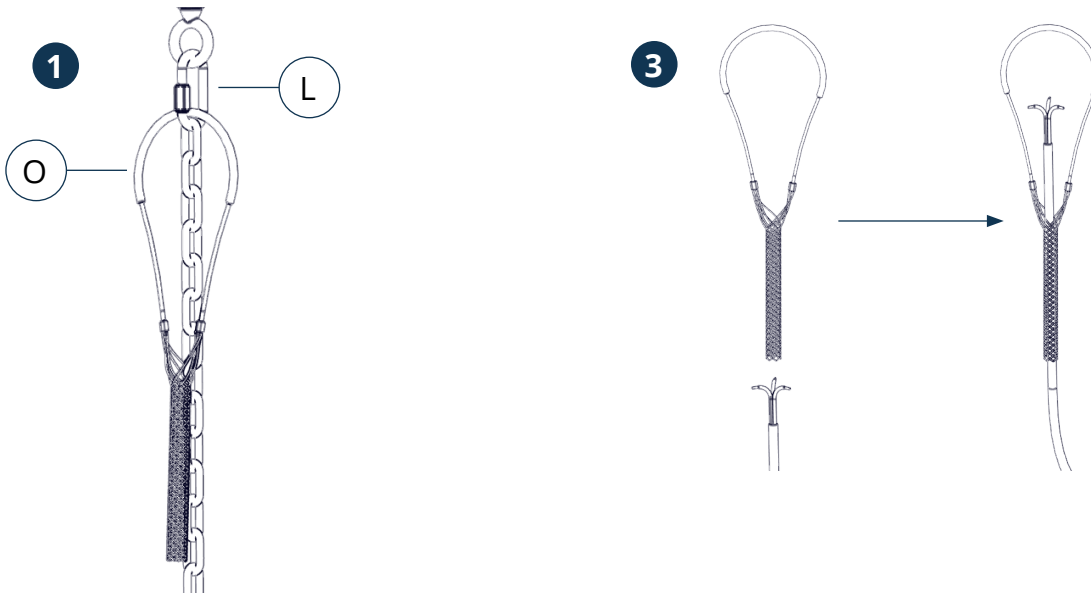

4. Continue to feed power cable through the cord grip (M) and out of the tank until all excess cord length has been taken up, leaving only enough so that there is no strain on the cable.
5. Tighten the top nut on the cord grip (M) to seal the power cable penetration.
6. Terminate the power cable into an exterior junction box (not supplied by Kasco).

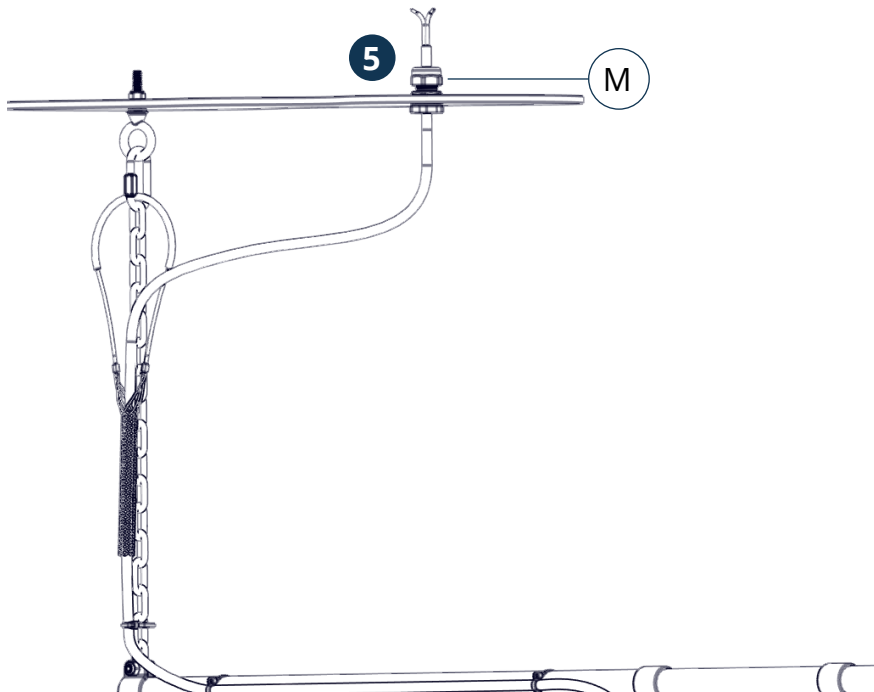

MIXER MAINTENANCE RECOMMENDATIONS



IMPORTANT: disconnect electrical power prior to any maintenance or servicing!

GFCI

GFCI (Ground Fault Circuit Interrupter) is a safety feature that can alert you to problems with the mixer. It is important to test the GFCI upon installation, after each re-installation, and regularly thereafter to ensure consistent operation. If you experience repeat interruptions, disconnect and remove the equipment. Inspect the power cord and unit (mixer) for damage. If no damage is apparent, please contact your Kasco distributor or representative for further instruction.

Observation

- Monitor the operating mixer for any reduction or variation in performance.
- Inspect the mixer annually and clean as needed to allow for heat dissipation and to verify that the propeller is clean and free of nicks.
- Inspect the power cable annually for damage or abrasion and replace as necessary.
- Regularly clean all external rotating parts and examine them for wear.
- If you note a deficiency in performance, remove the equipment from service and inspect for any damage or failure. If you observe any canister leakage during annual inspection, send the mixer to Kasco's factory for service and repair.

Cleaning

The stainless-steel motor housing needs to be kept clean in order to allow heat to effectively dissipate.

Seal and Oil Replacement

- Replacing the seal and changing the oil every 3-5 years will add reliability and longevity to the mixer.
- Seal replacement and all other repair services should be performed by Kasco Marine.

Electrical Troubleshooting

- If a unit fails to operate, you can use a series of simple checks to determine the general cause.
- Once you've located the fault, please contact your distributor for information on how to proceed with repair.

Is the GFCI Tripped?	<ol style="list-style-type: none">1. If yes, reset the GFCI and check operation.2. If the GFCI continues to trip, disconnect the unit in the panel and reset the GFCI.<ul style="list-style-type: none">• If the GFCI doesn't trip, the fault lies in the unit or its cord.• If the GFCI continues to trip, the fault lies in the control panel power source.
Is the cord damaged?	With the power off, perform a visual inspection of the power cord. If there is visible damage, contact your distributor for repair options.
What happens with an alternate power source?	If the power cord and unit appear to be in good condition, safely plug it into an alternate GFCI-protected power source. <ul style="list-style-type: none">• If the unit starts and runs, fault lies in the control panel or power source.• If the alternate GFCI continues to trip, fault lies in the unit or cord.

MIXER WARRANTY

Kasco offers a standard 3-year warranty with the following models:

- 2400C61
- 3400C61 / 3400HC61
- 4400C61 / 4400HC61
- 8400C61

At the time of purchase, a 5-year warranty is available for packages including Advanced model control panels.

Warranty must be purchased at the same time as the mixer package. (Mixer package consists of the mixer, mount, and control panel.)

Control panel MUST have GFCI protection.

Kasco® Marine, Inc. warrants this CertiSafe™ mixing system to be free from defects in material or workmanship under appropriate use and service. The Kasco Marine, Inc. obligation under this warranty is limited to replacing or repairing, without charge, proven defective part while within the warranty period. Customer shall pay shipping charges for returning the unit to Kasco.

THIS WARRANTY IS IN LIEU OF ANY OTHER WARRANTIES, EXPRESSED OR IMPLIED. IN NO EVENT WILL KASCO MARINE, INC. BE LIABLE FOR ANY CONSEQUENTIAL DAMAGES.

Warranty is void if:

- The mixer is not maintained according to the recommendations supplied in this manual.
- The mixer is returned for repair without the power cord.
- The unit, control box, or power cord are altered in any way from original shipment.
- The power cord is nicked or cut.
- The mixer is damaged by unauthorized service

Warranty Claim Procedure

Warranty period is established by the original receipt. For efficient service, please register the unit online at: kascomarine.com/warranty-registration.

Once warranty coverage has been established, you may send the unit to Kasco for evaluation and repair:

Kasco Marine, Inc.
800 Deere Rd.
Prescott, WI 54021
Attn: Repairs



Kasco only accepts complete assemblies for warranty repair. We must receive the power cord and all other components with the motor as originally assembled. Kasco will bill the customer to replace any missing parts necessary for repair. It is not necessary to return the control panel, mount, or other parts with the motor assembly, unless specifically requested by a Kasco representative.

Please attach a repair form with the shipment. The repair form must include a name, physical address (for return delivery of the repaired unit), daytime phone number, and an e-mail address for correspondence regarding the warranty claim.

Any expedited shipping method for the return of the unit is at the customer's expense. Kasco Marine will return units repaired under warranty at our expense via ground freight within the continental United States.

NON-WARRANTY REPAIRS

You can often repair failed equipment at a lower cost than replacement. Kasco Marine estimates repairs at the request of the customer. This request should include a daytime phone number and e-mail address.

Estimate options are as follows:

- Kasco contacts the customer with a repair total after we evaluate the unit, but before we perform the work quoted.
- Customer pre-approves repair of the unit if costs are below a stated dollar amount. Example: "Please repair if total is under \$150.00 before shipping charges."

Kasco will recycle any unit we receive for estimate but which the customer declines to repair, unless the customer specifies otherwise. If the customer would like the product returned, Kasco will return the unit to the condition in which we received it, and we will ship it at the customer's expense.

Billing

Contact Kasco to arrange payment for any non-warranty repairs. We will request payment information upon customer approval of the estimate.

CONTACT US



Kasco Marine
800 Deere Road
Prescott, WI 54021



715.262.4488



kascomarine.com | sales@kascomarine.com



Certified to
NSF/ANSI 61 & 372

REPAIR CONTACT FORM

- Kasco requires that all equipment sent for repair MUST be accompanied by this form and marked to Repairs attention.
- Unit should be cleaned before shipping.
- Kasco is NOT responsible for shipping damage accrued in return shipment.
- It is the responsibility of the customer to ship and pay freight to Kasco.

Kasco Marine
800 Deere Road
Prescott, WI 54021
Attn: Repairs

Note: Contact information should be that of the person or company to contact for repair information.

Company name			
Contact name	First name	Last name	
Address	Street		
	City		
	State		
	ZIP code		
Phone number	Primary	Alternate	
Email address			
Preferred method of contact (circle one)	Phone	Email	
Purchase order number			
Additional product information	Serial Number	Cord Length	
Information for Repair Technician			
Was this unit used in a chemical treatment or wastewater application? (circle one)	Yes	No	
Additional notes			