

AMMONIA-SCALE™

FOR 150 LB AMMONIA CYLINDERS

PVC PLATFORM
WILL NEVER CORRODE

SMALL FOOTPRINT
FOR LIMITED SPACES

LOW PROFILE
FOR EASY LOADING &
UNLOADING

KEYPAD & MENU DRIVEN
DIGITAL DISPLAY

The Ammonia-Scale™ from Force Flow allows 150 lb ammonia cylinders and other similarly sized compressed gas cylinders to be accurately monitored for usage and inventory control. The low profile cylinder weigh platform is made from solid PVC with no internal components such as suspension systems that can corrode and fail. The small footprint of each scale platform allows the scale to be installed in even the most limited spaces. Independent platform design allows each cylinder location to be set as desired. Unlike disc type weigh platforms that require the operator to insure that no part of the cylinder is touching the fixed portion of the base, with the Ammonia-Scale the operator simply pushes the cylinder against an adjustable backstop for quick, guaranteed correct positioning. Included chaining brackets provide cylinder restraint and a convenient place for storing change-out tools. The Ammonia-Scale can monitor any cylinder with a diameter from 13 to 19 inches and a gross weight up to 400 lb.

The Ammonia-Scale includes either the SOLO G2® or the WIZARD 4000® digital weight indicator depending on the level of information desired. Both indicators show the weight of the remaining ammonia on a backlit LCD, dual line, alphanumeric display. A digital bar graph also visually indicates percent full for quick assessment. The Wizard 4000 provides additional chemical inventory and feed information such as days until empty, amount fed and feed rate. All configuration and operations for both indicators are performed using the keypad with easy to follow menu prompts on the display. No function or adjustment ever requires the hassle of opening the enclosure to gain access to confusing DIP switches or potentiometers, insuring the enclosure remains sealed against the elements.

Both indicators have a dedicated tare/tank load key that allows the operator to choose from NET/AUTO or TARE/MANUAL entry during cylinder change-out. Net mode allows the operator to instantly set net weight to an amount representing the contents of a full cylinder. All other weight on the scale, such as empty cylinder weight and process connections, is simply stored as tare weight. If a cylinder is partially full or has an unknown amount of ammonia inside, the operator selects tare/manual mode, is prompted to enter the weight of the empty cylinder, and then the difference between gross weight and tare weight is displayed as net weight. No manual calculations are required.



WIZARD 4000®



SOLO G2®



AMMONIA-SCALE

ELECTRONIC SCALE FOR 150 LB AMMONIA CYLINDERS

MODELS & ORDERING INFORMATION

MODEL	WR400-1AS	GR400-1AS	WR400-2AS	GR400-2AS
PLATFORM				
NO. OF PLATFORMS	ONE (1)		TWO (2)	
MAX CAPACITY (EA. PLATFORM)	400lbs			
MATERIAL	SOLID PVC w/STAINLESS HARDWARE			
LOAD CELL	SEALED ANODIZED ALUMINUM w/10 FT CABLE*			
CHAINING BRACKET	ONE (1)		TWO (2)	
INDICATOR				
MODEL	WIZARD 4000	SOLO G2	WIZARD 4000	SOLO G2
DISPLAY INCREMENTS	0.1 lb (0.05kg)			
ENCLOSURE	NEMA 4X STRUCTURAL FOAM MOLDED, UL LISTED			
INPUTS	(1) mVDC LOAD CELL SIGNAL		(2) mVDC LOAD CELL SIGNALS	
OUTPUTS	(1) 4-20mA, SOURCING		(2) 4-20mA, SOURCING	
OPERATING TEMP	32F to 122F (0C to50C)			
POWER	110-240VAC, 47-63Hz, 1/4 AMP			
INDICATOR OPTIONS				
RELAYS	UP TO (4) DRY CONTACT RELAYS			
SERIAL COMM	RS485 MODBUS ASCII, TCP/IP ETHERNET and PROFIBUS DP			
OTHER				
OVERALL ACCURACY	1% OF FULL SCALE			
SHIPPING WT	40 lb (18 kg)	36 lb (16 kg)	71 lb (32 kg)	66 lb (30 kg)
WARRANTY	FULL 5-YEAR			

*Additional cable length available

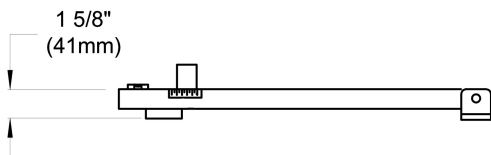
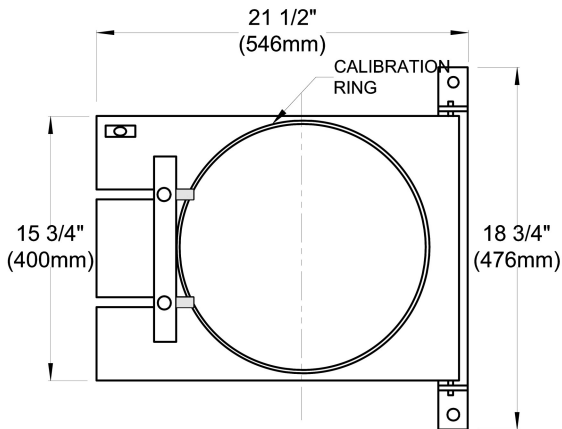

WIZARD 4000®
Digital Weight Indicator
See bulletin 400 for more information



SOLO G2®
Digital Weight Indicator
See bulletin 516 for more information

