



BEACON

WATER TECHNOLOGIES

Pile Cloth Disk Filtration Systems

GDisk® Models

Available in four different models, all offered in concrete and package steel (304SS, 316SS, or painted carbon)



Model	Disk Diameter	Max Capacity Unit	Segments/Disk	Max # Disks/Unit
GDisk®-Giant	9.8 ft (3.0 m)	13.2 MGD	8	24
GDisk®-Standard	7.2 ft (2.2 m)	6.60 MGD	6	24
GDisk®-Mini	3.9 ft (1.2 m)	0.90 MGD	4	12
GDisk®-XS	3.0 ft (0.9 m)	0.16 MGD	4	6

GDisk® Operation Mode

FILTRATION

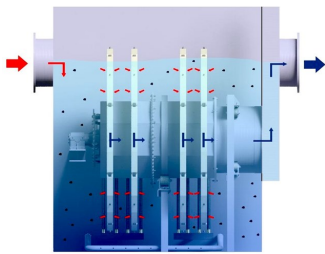

- Pass through media by gravity
- Removing Solids accumulated on the disk surface, forming a mat
- Filtered water flow through from the inside of center tube to the outlet

BACKWASH

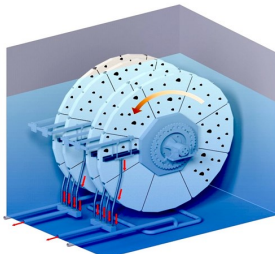

- Operated by level switch or timer
- Low pressure suction on the front and back side of the pile cloth disk
- Non-stop filtration during backwash

SLUDGE DISCHARGE

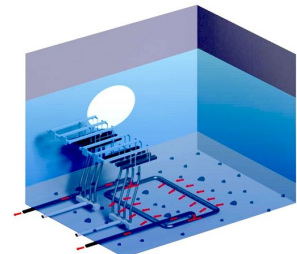

- Sludge sediments on the bottom
- Automatic discharge of bottom sludge
- Flexible response to incoming shock load

Floating scum is evacuated into a dedicated trough for primary and wet weather application models.

Dual-Slot Backwash Manifold

- A main slot and a primary slot are provided in parallel by a partition
- Pile threads undergo delayed straightening and fluctuation while going through the primary slot. The main slot then straightens pile threads rapidly
- This patented dual-slot backwash manifold increases backwash efficiency and minimize backwash water volume

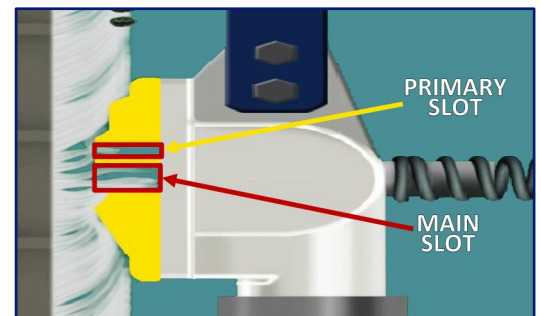

PO Box 22097
Charleston, SC 29413

843.481.4470
info@beaconh2o.com

www.beaconh2o.com

