



TRASH FLOW[®] PRE-PACKAGED LIFT STATIONS

Above ground, below ground, auto-start,
bypass pump systems



RELIABLE. EXPERIENCED. FULLY CUSTOMIZABLE.
TRASH FLOW® LIFT STATIONS FOR MUNICIPAL AND INDUSTRIAL APPLICATIONS.



For wastewater lift station requirements, trust the experts in sewage and solids handling pump manufacturing at Wastecorp.

Wastecorp has a 30 year track record manufacturing lift stations for municipal and industrial pumping applications.

Wastecorp Pumps is an ISO 9001 and 14001 certified lift station manufacturer adhering to Hydraulic Institute standards. Wastecorp created Trash Flow packaged, fully customizable

above ground, below ground and auto start lift stations as the next generation solution for managing higher volume waste water pumping needs of municipal, industrial, hotel and resort and water park pumping needs.

Wastecorp designs and manufactures your entire packaged lift station from the pumps to NEMA control panels. Specialized accessories like enclosures are available for any Wastecorp lift station model and protects your investment from weather and vandals.

Look to a leader in lift station manufacturing with unmatched quality and service. That's Wastecorp Trash Flow lift stations.

FIVE REASONS WHY YOU SHOULD SELECT TRASH FLOW® LIFT STATIONS

The days of the cookie cutter approach to lift station design and manufacturing are over. One of the biggest advantages in working with Wastecorp is that we design your lift station requirement to your application and specification. Standard sizes are also available if required.

LIFT STATION SPECIFICATION ASSISTANCE

Wastecorp lift station specialists work with end users, municipalities and consulting engineers to understand your application and challenges. We put together a proposal using the latest engineering software to get you everything you need for the project.



PRE-PACKAGED LIFT STATION DESIGN

Not every application or lift station is alike. That's Why Wastecorp lift station experts are your go-to solution. With a lengthy track record in municipal and industrial pump application we match the pumps, NEMA controls, piping, valves and accessories that you need.

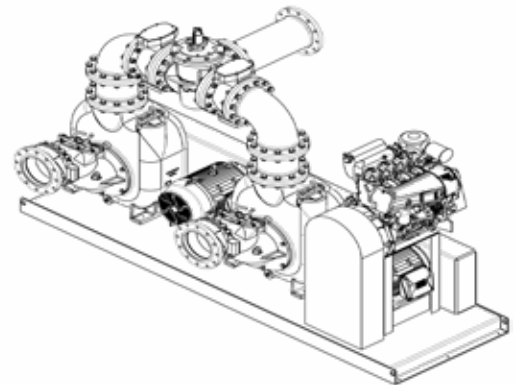

LIFT STATION MANUFACTURING

Wastecorp's new state-of-the-art pump manufacturing facility has the resources to get your pump station completed when needed. All Wastecorp lift stations are manufactured by our technicians with an average of 15 years in the industry.

LIFT STATION TESTING

Wastecorp Trash Flow lift stations are rigorously tested before delivery to you. We are guided by Hydraulic Institute testing standards and our ISO 9001 certification. Since every application is different we test under your various conditions so that the lift station operates as expected.



Shown: Trash Flow piggy back pump station with two 4" TFCC Series pumps and NEMA controls.

LIFT STATION INSTALLATION

All of our lift stations ship pre-packaged from Wastecorp's manufacturing facility ready for professional installation. Optional on-site factory support is available.

TRASH FLOW® STANDARD ABOVE GROUND LIFT STATION FEATURES



1-PUMPS

Accommodates Trash Flow® self-priming TFCC Series pumps in duplex and triplex configurations:

Trash Flow Pumps:

Sizes 3"- 8" in duplex arrangements up to 100 HP

Sizes 3"- 4" in triplex pump arrangements

2-ENCLOSURE

Manufactured for flexural strength, excellent fatigue and delaminating resistance

3- MAINTENANCE ACCESS

4-REMOVABLE ROOF

5-MAN-DOOR STATION ENTRANCE

6- INTERIOR WALL FOR ACCOMMODATING MORE SOPHISTICATED CONTROLS

7- CUSTOM-ENGINEERED, NEMA-RATED AUTOMATIC CONTROLS:

Includes your choice of adjustable pressure controls, H-O-A selectors, overload reset buttons and circuit breakers for station accessories Available U.L. and C.S.A. listed

8- CLEARLY MARKED FIELD CONNECTIONS FOR FAST AND EFFICIENT ELECTRICAL HOOK-UP

SPECIFICATIONS

Pump Size: 3" (75 mm), 4" (100 mm), 6" (150 mm), 8" (200 mm)

Max. Capacity: 2600 GPM

Max. Solids: 3" (76.2mm)

Max. Head: 320' (97.5 m)

Max. Temperature: 160°F (71°C)

Motor - Voltage: 200V 3p, 230V 1ph, 230V 3 ph, 460V 3 ph

Motor Cycles: 60 Hz

Horsepower: 2 hp - 100 hp

LIFT STATIONS FOR THE ULTIMATE PACKAGED PUMPING SOLUTION.

Wastecorp Pumps provides a complete line of pre-engineered packaged pump stations for any type of water and wastewater lift application. Select from above ground, below ground and auto-start pump stations. The Wastecorp Trash Flow provides a patented shimless adjustable wear plate carrier which comes standard on every pump station. For many municipal or industrial applications, a packaged and factory engineered lift station or booster station is the best choice. Each factory built station can be housed in a corrosion and mildew resistant fiberglass case that offers an easy lift off canopy design and large access hinged door for easy maintenance, cleaning and repair.

Above Ground Lift Station Options



Shown: Trash Flow lift station with TFCC -6 Series trash pumps with custom piping and valves. Custom NEMA control panels with low level/high level alarm for floats.



Standard Configuration



Piggy Back

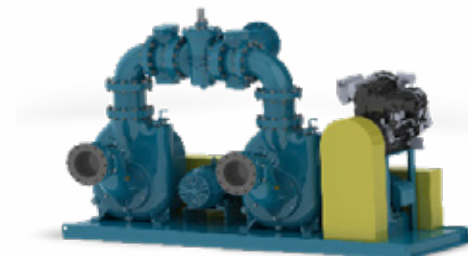

Auto-start Modular Lift Stations

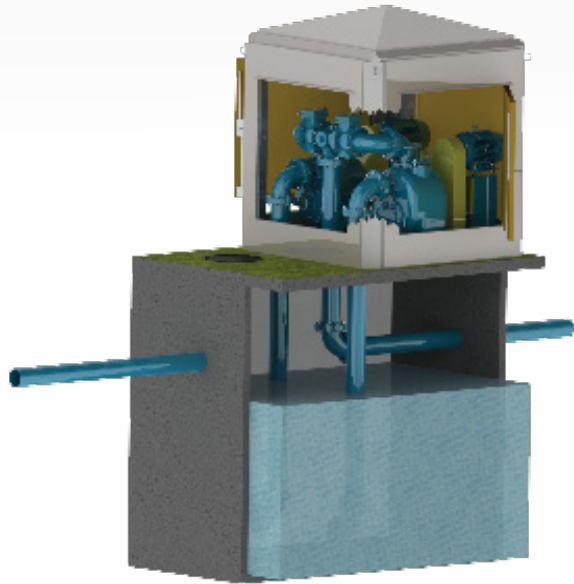

TRASH FLOW® ABOVE GROUND LIFT STATIONS

Wastecorp's factory assembled, pre-engineered above ground pumping stations are available with a wide variety of piping configurations, motor options, control panels and accessories.

You select your Trash Flow self priming centrifugal pumps ranging from 2"-12". Configurations are available from duplex or triplex designs.

Specifications

Available connection sizes :	2",3", 4", 6", 8", 10", 12"
Max. capacity:	6300 GPM (397 lps)
Max. head:	150' (46 m)
Max. temp.:	160°F (71°C)
Max. solids (in):	3" (76.2 mm)
Voltage:	200 V 3 phase, 230V Single phase, 230V 3 phase, 460V 3 phase



TRASH FLOW® AUTO START LIFT STATIONS

Auto-start lift stations are designed with DC controls and a standby engine to provide pumping service during power outages. The entire package includes control panels, engines and of course your choice of genuine Trash Flow® 3", 4",6",8", 10" pr 12" pump sizes.

For higher flow applications, triplex or quadruplex pump configurations are available. Wastecorp engineering staff is able to assist in design and implementation of your pump system.

Specifications

Available connection sizes :	2",3", 4", 6", 8", 10", 12"
Max. capacity:	6300 GPM (397 lps)
Max. head:	150' (46 m)
Max. temp.:	160°F (71°C)
Max. solids (in):	3" (76.2 mm)
Voltage:	200 V 3 phase, 230V Single phase, 230V 3 phase, 460V 3 phase



Shown: Below ground lift station with two pump configuration (piggy back)

TRASH FLOW® BELOW GROUND LIFT STATIONS

A below ground lift station is a type of pump system buried below ground in residential areas to transfer wastewater and municipal sewage.

The pumps that transfer the wastewater are trash pumps enclosed in a mildew resistant container called an enclosure. There are various controls built in to the pump system to control pressure and provide warnings to public works officials of too much pressure or other trouble with the equipment.

Specifications

Available connection sizes :	2", 3", 4", 6", 8", 10", 12"
Max. capacity:	6300 GPM (397 lps)
Max. head:	150' (46 m)
Max. temp.:	160°F (71°C)
Max. solids (in):	3" (76.2 mm)
Voltage:	200 V 3 phase, 230V Single phase, 230V 3 phase, 460V 3 phase

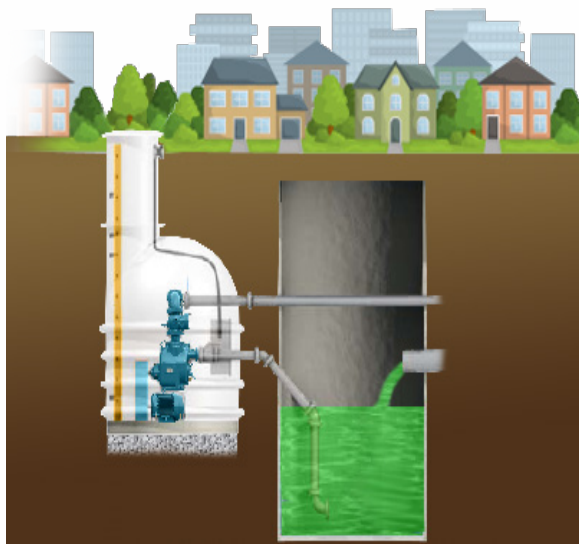

Trash Flow® Pumps

- 2"-12" connection sizes available
- Each pump capable of 260-5500 GPM (model dependant)
- Municipal and industrial wastewater handling
- Select from duplex-triplex pump arrangements
- Adjustable wear plate carrier
- No need for elevators or platforms

Controls

- NEMA rated controls with several custom warning system options available
- Options include adjustable pressure control, circuit breakers and overload reset systems
- U.L. and CSA listed (Contact factory for details)
- Control panels/connections are clearly labelled for contractor installation

Optional Enclosure

- Designed to withstand mold, fungus, mildew
- Customize your enclosure
- Manhole opening can be locked for added security
- Select from three color options

Warranty

- Several warranty options available for pumps, controls and optional enclosure

North America: 1-888-829-2783

Fax: 1-888-883-3320

Worldwide: +1-201-445-2882

Fax: +1-201-445-3252

E-mail: info@wastecorp.com

Internet: www.wastecorp.com

LIFT STATION EXPERTS WITH DECADES OF EXPERIENCE.

Customer satisfaction, state-of-the-art manufacturing methods and engineering expertise are just a few of the reasons you should consider Trash Flow lift stations. Manufactured by Wastecorp Pumps in the United States and Canada parts and service if required are available within 24 hours



Specifications, literature and illustrative material in this trash pump brochure are accurate at the time of publication but are subject to change without notice. Illustrations may include optional equipment and accessories and may not include all standard equipment. Wastecorp and globes are trademarks of WPI/Wastecorp Pumps. Wastecorp Pumps is the exclusive manufacturer of these brands worldwide under license. Marks are protected in North America and worldwide.

© 2018 WPI. All rights reserved. New York, NY 10024.
NYC/West85 Djs 10/18. Litho in the United States of America.
For a complete engineering specification contact Wastecorp Pumps at
1.888.829.2783 or by E-mail: info@wastecorp.com.

Also on the web at <http://www.wastecorp.com> Wastecorp is not affiliated with the companies listed above. Names used for reference purposes only. All trademarks are the property of their respective owners.