

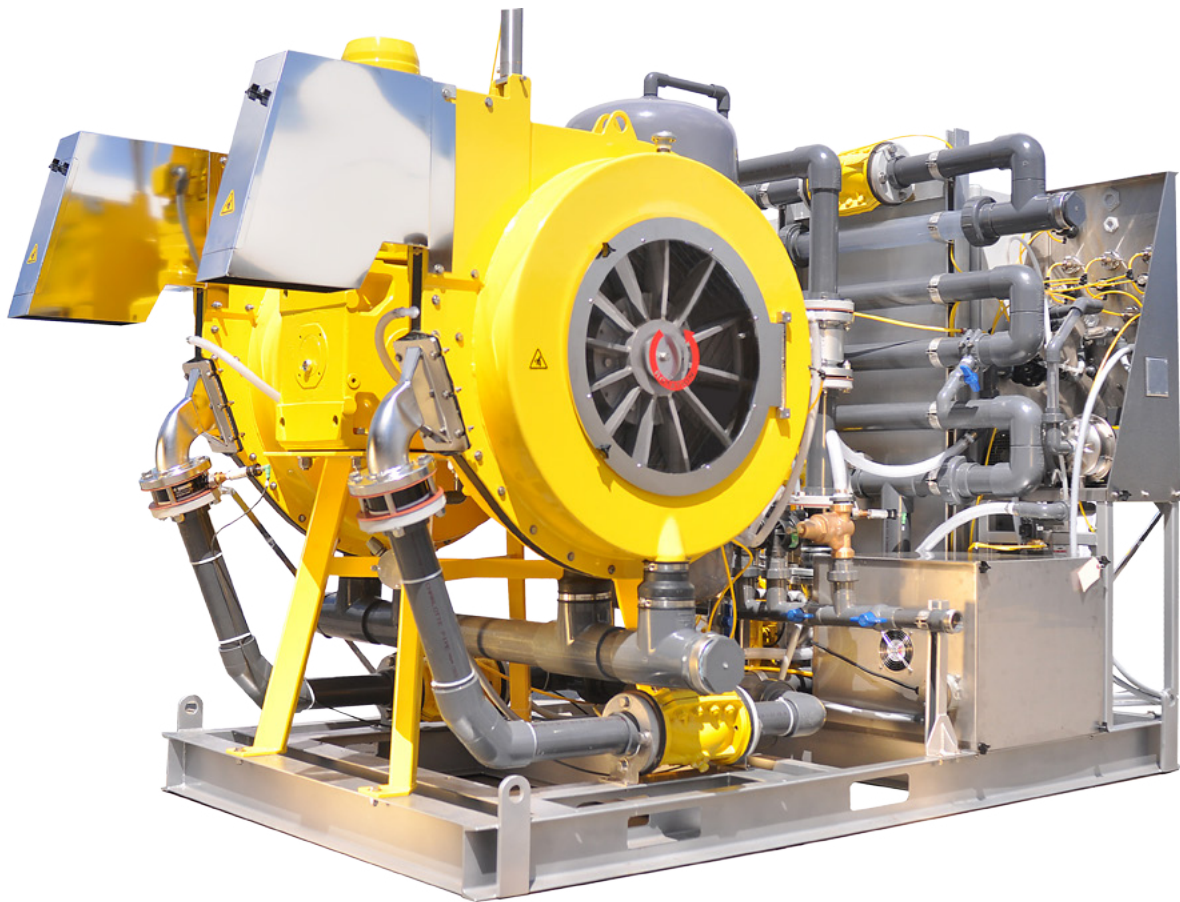

PRIME
SOLUTION

DEWATERING PERFORMANCE SIMPLIFIED

THE PRIME ROTARY FAN PRESS FAMILY



HIGH PERFORMANCE, COST EFFECTIVE ROTARY FAN PRESSES

Prime Solution designs, manufactures and services dewatering equipment. Our technology is designed and built in Michigan, in the heart of the USA.

ROTARY FAN PRESS • ROTARY FAN PRESS 2.0 • ROTARY FAN SCREW PRESS

SERVING INDUSTRIES WORLD WIDE

FAMILY FARM TO GLOBAL LEADER



With a humble start on a family farm in the mid-west, Prime Solution has evolved into a global leader in dewatering solutions with one mission: Design and manufacture operator-friendly, simple, yet effective dewatering solutions that meet or exceed the needs and wants of our customers.

- Headquartered in Otsego, MI
- Manufactured in the USA
- 30+ years of reliability and innovation.
- Skid, trailer, and free standing systems
- Dedicated customer service department
- Feasibility testing
- On-site pilots



OVER 30+ YEARS AND OVER 160 INSTALLATIONS WITH LESS THAN 0.5% IN PARTS SALES. MORE UP TIME AND LOWEST COST OF OWNERSHIP.

We engineer from an operator's perspective — simple is better. Over the years, sludge dewatering requirements have changed along with sludge processes. Our family of Rotary Fan Presses has expanded to exceed these requirements while maintaining proven operational advantages, higher cake solids and capture rates along with capital saving of the lowest footprint per lbs of solids dewatered.

All of our rotary fan presses use a patented screen technology that uses simple pressure differential and friction resistance to provide superior dewatering

performance at a lower cost and prolonged service life. The totally enclosed dewatering process has slow operation speeds of <1 rpm, minimal wear parts, produces high cakes solids and excellent filtrate. Low operational costs, minimal or no manpower required, and low energy and water use provide savings year over year. Models are available in several sizes ranging up to 260 gpm hydraulically, in a small footprint, and most models have the ability to accommodate additional channels for future increased throughput requirements.





THE ONE AND ONLY

The only dewatering device with patented screen technology that uses simple pressure differential and friction resistance to provide superior dewatering performance at a lower cost and prolonged service life. The totally enclosed dewatering process has slow operation speeds of <1 rpm, minimal wear parts, produces high cake solids and excellent filtrate. Low operational costs, minimal or no manpower required, and low energy and water use provide savings year over year. Models are available in several sizes ranging up to 260 gpm hydraulically, in a small footprint, and most models have the ability to accommodate additional channels for future increased throughput requirements.



SIMPLE AND EFFECTIVE

- Patented screen technology and fundamental physics.
- Friction and pressure to force liquid out the path of least resistance.
- Conditioned sludge is fed into the dewatering channel between two slow moving (<1 rpm) parallel stainless steel filter screens.
- Friction intensifies as the solids compress against the filter screens, causing liquid to take the path of least resistance and drain through the screens.
- The remaining solids collect in the annular space between the filter screens and advance towards the discharge end of the press.

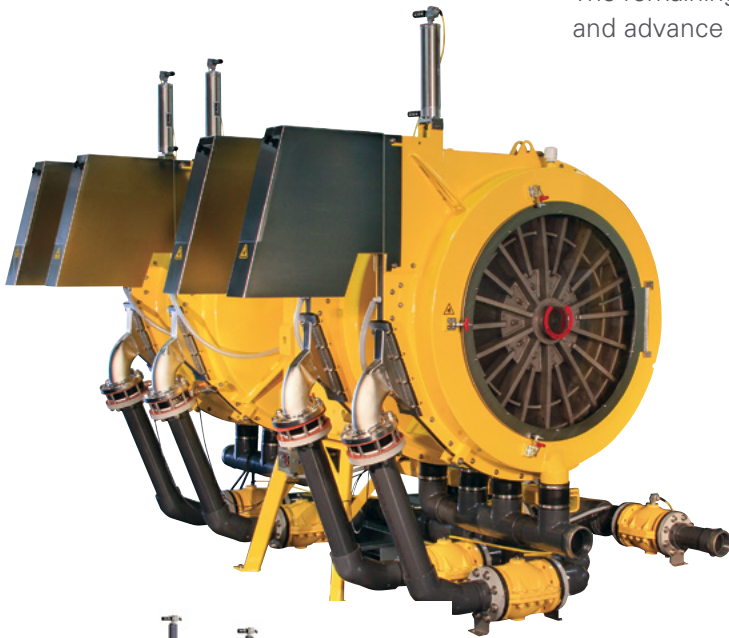

PRIME ROTARY FAN PRESS® *patented*

- Lowest maintenance and cost
- Expandable throughput
- High cake solids and capture rates
- Proven technology
- Easily automated
- Easy start up and shut down
- Retro-fit without expansion
- Low speed

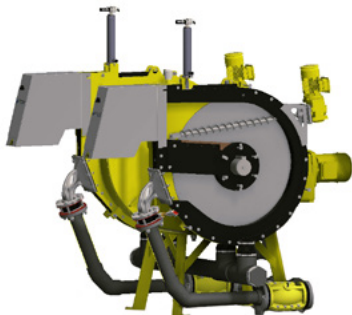

PRIME ROTARY FAN PRESS 2.0 *patented*

Revolutionary. All the benefits of the original Rotary Fan Press, plus:

- Designed for sludge that releases moisture at a slower rate.
- Ultra-advanced, simplified low-shear dewatering device with a patented internal mixing element.
- Drier cake solids with higher throughputs at a lower cost.



PRIME ROTARY FAN SCREW PRESS® *patent pending*

The best of both worlds. All of the benefits of the original Rotary Fan Press coupled with the benefits of a screw press, results:

- Higher throughput and cake solids in a smaller footprint.

SO SIMPLE IT'S GENIUS.

HOW IT WORKS.

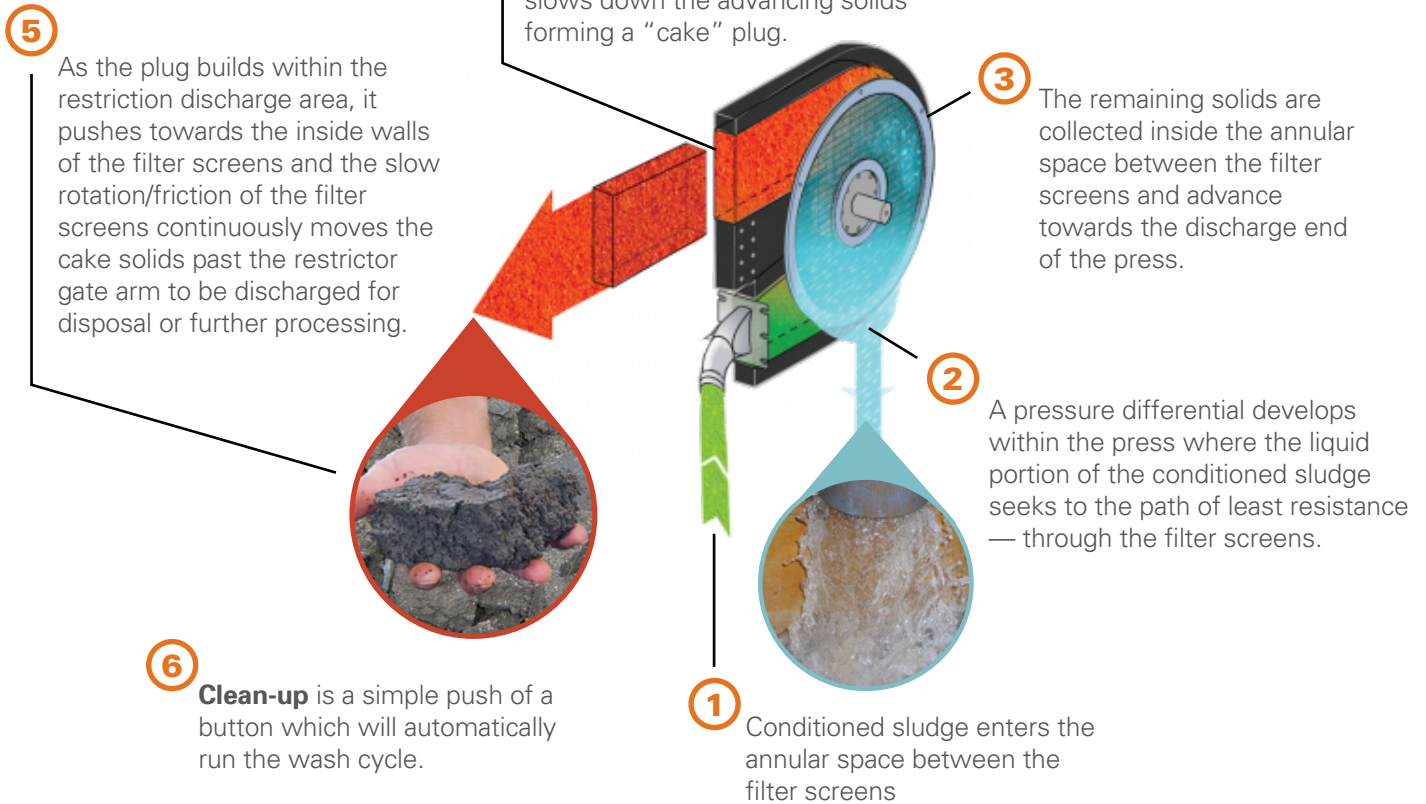

The totally enclosed, slow moving (<1 rpm), small footprint design with the lowest maintenance of any mechanical dewatering technology provides for long sustainable dewatering. The unit is controlled by a PLC touch screen which provides fine adjustments, allowing infinite control of the unit and accurate detailed refinement of the operating parameters. The operator has the option to control the dewatering process from the sludge feed all the way through to the sludge cake transfer, thus interlocking the entire system for semi-automatic operation.

NOT ALL SLUDGE IS CREATED EQUAL.

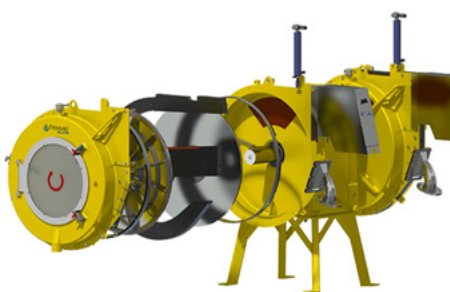

The Prime Rotary Fan Press

was designed to handle most common sludges, producing high cake solids and capture rates, while requiring less space, power and maintenance. Its strength is in its simple design.

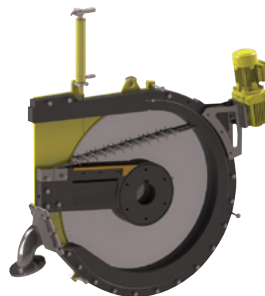

The Prime Rotary Fan Press 2.0

was designed for sludge that releases moisture at a slower rate. This ultra-advanced, simplified low-shear dewatering device with a patented internal mixing element will give you drier cake solids with higher throughputs at a lower cost.

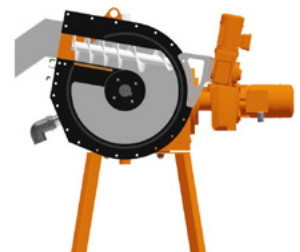

The Prime Rotary Fan Screw Press®

is ideal if you need larger throughput in a smaller space. The RFSP uses the same reliable technology of the Prime Rotary Fan Press®, with the added technology of an additional compression zone and screw press technology. It's the best of both worlds.

SIZES AND CAPABILITIES

FREE STANDING UNIT – ROTARY FAN PRESS, ROTARY FAN PRESS 2.0, AND ROTARY FAN SCREW PRESS.

MODEL	CHANNELS	FILTRATION AREA (ft ²)	PRESS DRIVE HP	APPROX. LENGTH (ft.)	APPROX. WIDTH (ft.)	APPROX. HEIGHT (ft.)	APPROX. WEIGHT (lbs)
RFP24S	1	4.28	1.5	6	4.5	5.5	2,100
RFP24D	2	8.56	1.5	6	4.5	5.5	2,600
RFP36S	1	10.32	3	7.5	5.5	6.5	2,400
RFP36D	2	20.64	3	7.5	6	6.5	3,600
RFP36DE	2 (expandable)	20.64	5	8	6	8	6,600
RFP36T	3	30.96	5	8	8	8	8,300
RFP36Q	4	41.28	5	8	9.5	8	9,800
RFP48S	1	18.82	5	8.5	5.5	8	6,400
RFP48D	2	37.64	5	8.5	6.5	8	8,500
RFP48DE	2 (expandable)	37.64	7.5	9.5	6.5	8.5	9,500
RFP48T	3	56.46	7.5	9.5	8	8.5	11,800
RFP48Q	4	75.28	7.5	9.5	10	8.5	14,200



THE PRIME ADVANTAGE

- Proven technology
- Space savings and simple installation
- Easily retro-fits plants without building expansion
- Low energy, LOWEST maintenance (less than .5% over 20 yrs)
- Easy startup/shutdown
- Easily automated
- High cake solids and capture rates
- Expandable throughput without replacement
- QUICKEST ROI (see previous points)
- Ongoing innovation
- Excellent customer service and support

SPECS

- 24, 36, and 48 inch diameter
- Sludge Cake Conveyors
- One to Four Dewatering Channels
- Emulsion Polymer Systems
- Free Standing/Skid Mounted/Mobile

APPLICATIONS

- Municipalities
- Industrial
- Food
- Agricultural
- Gas, Oil and Mining

SERVICES AND ANCILLARY EQUIPMENT



LABS

Will the Prime Rotary Fan Press meet your dewatering requirements? Find out before you make a capital investment. Our no-cost wet lab will determine the effectiveness of the Prime Rotary Fan Press on different applications. Prime will provide sample containers at no cost and generate a report for your review.



PILOT TESTING

After we've determined the effectiveness of the Prime Rotary Fan Press on your particular application, the next step is to see it in operation at your facility.

Prime Solution will bring our mobile trailer to your facility for a demonstration of its functionality. Analysis of your cake solids and filtrate is performed in our lab, allowing you to select the right chemistry and the right equipment to achieve the highest cake solids possible, matching the right equipment to your application to maximize dewatering results. At the conclusion of the on-site demonstration Prime will provide a comprehensive report of the demonstration results.



PRIME SERVICES

At Prime Solution we pride ourselves on exceeding excellence, striving to always provide our customers with superior service. Customized Service Maintenance Programs, New Employee and Refresher Training, Equipment Upgrades, and On-site Support are offered to maximize and enhance the operating and efficiency of dewatering products.



PRIME CONVEYORS

Not only can Prime Solution customize your dewatering needs, but we can also customize the way that you handle cake solids transference. We offer multiple sizes and styles of conveyors to fit your application. With our rugged stainless steel construction and simple maintenance, you can be assured of many years of reliable and uninterrupted service.

LEARN MORE. Please contact us if you would like to learn more about Prime or to speak to a salesperson.



PRIME
SOLUTION

MICHIGAN
610 S. Platt St.
Otsego, MI 49078
269.694.6666

psirotary.com

